

MotorGuide® REPAIR PARTS

Model:
680V

SPECIFICATIONS:

Year of Intro	1999
Thrust	80 LBS
Volts	24VDC
Amp Draw	0 to 33amps
Mount	20 Bow
Speeds	Variable

PARTS ORDERING & TECH ASSISTANCE

MotorGuide Consumer Relations
Phone 918-831-6989
Fax 800-982-8093

Returned Goods must be accompanied with a Returned Goods Authorization. Contact MotorGuide Consumer Relations to obtain RGA.

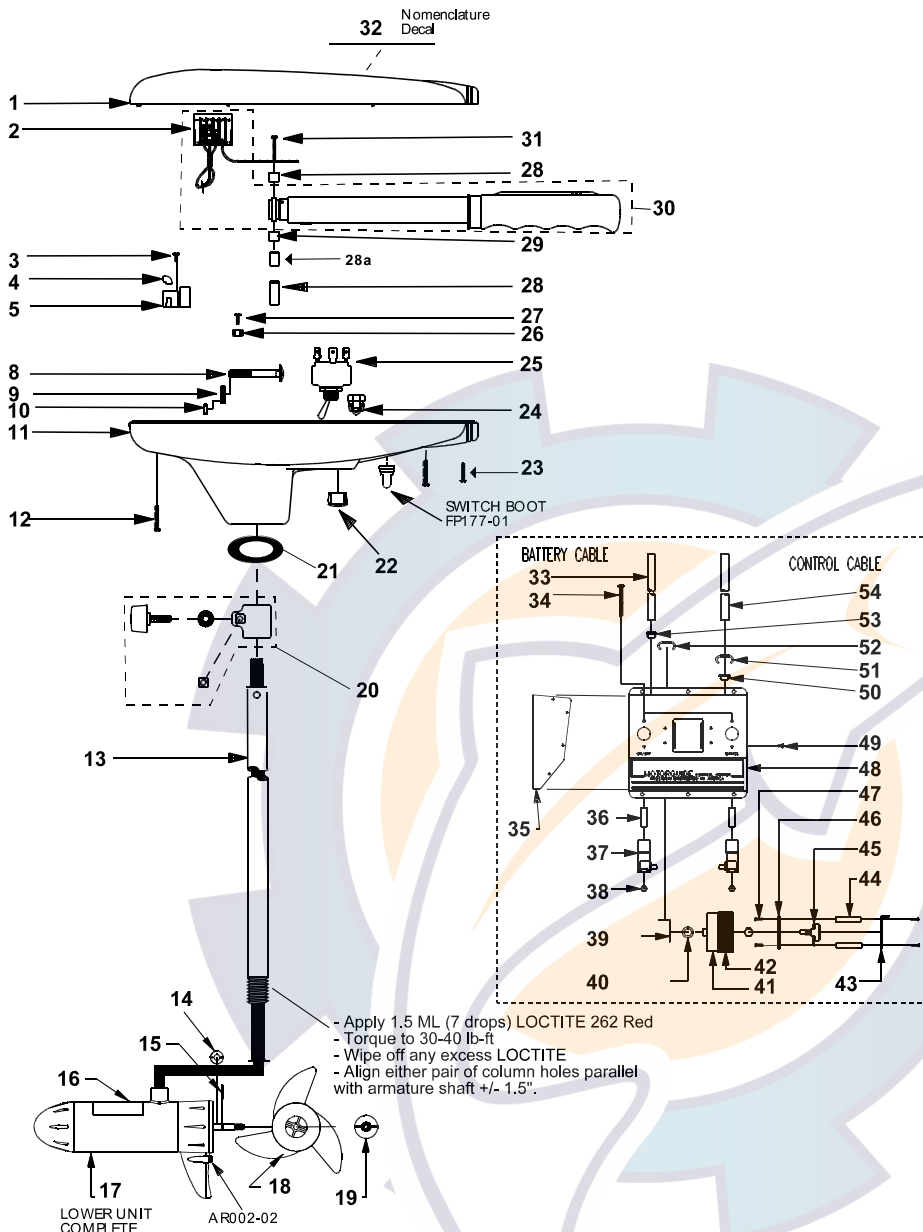

KEY	DESCRIPTION	PART #	KEY	DESCRIPTION	PART #	KEY	DESCRIPTION	PART #
1	TOP HOUSING COVER BLACK	AT053-18	27	SCREW #10 X 1/2	RT133-03	52	RING CLAMP	AP040-01
2	AMP CONNECTOR	AP029-01	28	WIRE BRACKET	AT155-04	53	BUSHING, BATTERY CABLE	FP040-01
3	SELF TAPPING SCREW	XT141-01	28a	HANDLE BOSS BUSHING	AT022-01	54	CONTROL CABLE	FP327-04
4	INSULATING SLEEVE	AT080-01	29	RETAINER CLAMP	AR036-02	ITEMS NOT SHOWN		
5	DURA AMP BOARD	AT157-03	30	HANDLE ASY	AR372-11	FOOT BOX ASY COMPLETE		PP300-06
8	BOLT	TT134-01	31	8 X 1-3/8 SCREW	RT133-01			
9	CURVED WASHER	TT171-04	32	NOMENCLATURE	FR056-12			
10	NYLON LOCK NUT	XT098-02	33	BATTERY CABLE	AP328-09			
11	T/H BASE BLACK	AR004-14	34	SCREW	BK135-03			
12	SCREW #8 X 1"	LF141-04	35	FOOT BOX BASE	FP004-01			
13	COLUMN 42"	FR049-15	36	SPACER	MM1007-01			
	COLUMN 50"	FR049-13	37	FOOT SWITCH	FP149-01			
14	MONOFILAMENT WASHER	AR175-01	38	DISPLAY RAIL NUT	BK098-01			
15	PROP DRIVE PIN	BR102-02	39	SWITCH SUPPORT PLATE	FP155-01			
16	LOWER UNIT DECAL	AF060-07	40	NYLON WASHER	PP171-01			
17	H/O MOTOR	TF397-01	41	DECAL, ROTARY KNOB	AP057-07			
18	PROP	AF124-11	42	ROTARY KNOB	AP082-02			
19	PROP NUT	AR099-01	43	SWITCH SUPPORT PLATE	FP155-02			
20	DEPTH COLLAR ASY	AR158-01	44	SWITCH STANDOFF	AP102-02			
21	COLUMN SEAL	AT079-01	45	POTENTIOMETER	AP168-02			
22	HOLE PLUG	FP021-03	46	BUSHING	AP012-01			
23	SCREW	FR135-01	47	SCREW	BK136-01			
24	GROMMET	FP021-01	48	FOOT BOX COVER	FP353-03			
25	FWD/REV SWITCH 2 POSITIONS	FP153-06	49	SCREW	BK135-01			
	VARI/OFF TOGGLE SWITCH	FP153-08	50	BUSHING, CONTROL CABLE	FP021-01			
26	ON SERT NUT	TT098-03	51	RING CLAMP	AP040-01			

Model:
680V

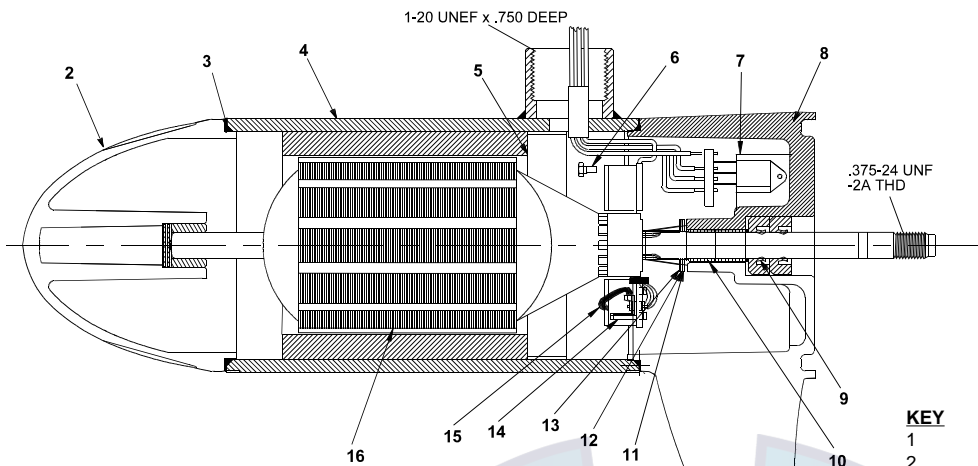

DIRECTION OF ROTATION IS COUNTER CLOCKWISE WHEN VIEWED FROM PROPELLER END WITH RED POSITIVE & BLACK NEGATIVE.

NOTE: TORQUE MOSFET BOLTS TO 35 TO 40 INCH LBS.

NOTE: TORQUE THRU BOLTS TO 40 TO 50 INCH LBS.

KEY	QTY	DESCRIPTION	PART NO.
1	X	MOTOR	TF397-01
2	1	NOSE CAP	XF3212-01
3	2	O RING SEAL	MR217-01
4	1	HOUSING ASY	AF3210-06
5	1	RETAINER	JF233-01
6	2	BRUSH CARD SCREW	MR228-01
7	1	DURA AMP MODULE	JF096-09
8	1	COMM CAP	XF3205-01
9	2	SHAFT SEAL	MR223-01
10	1	BEARING	MR206-01
11	1	NYLATRON WASHER	MR226-01
12	1	WASHER	MR227-01
13	1	E RING	MR219-02
14	2	BRUSH SPRINGS	XF214-01
15	1	BRUSH ASY LESS SPRING	XF3201-01
16	1	ARMATURE	TF3207-01
17	4	STATIC SEAL	MR222-01
18	4	THRU BOLT WASHER	MR216-02
19	2	DURA AMP SCREW	MR229-04
20	2	THRU BOLT	MR218-02

WIRING

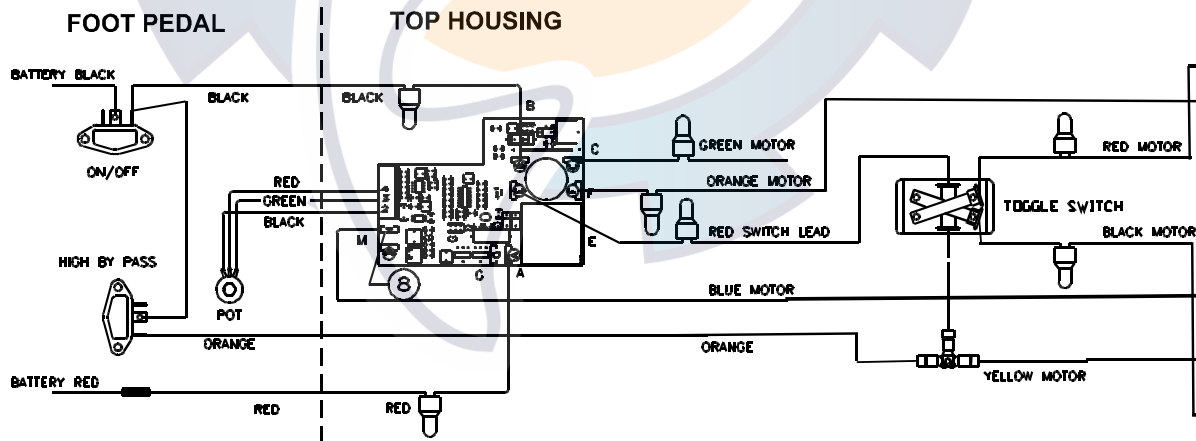

SUBJECT TO DAMAGE BY STATIC ELECTRICITY
ASSEMBLE AT STATIC FREE WORK STATION!